



© Tim Van de Velde

Introduction

This Léém Clay Plasters & Paint guide aims to provide trustable information to the building professional (architect, engineer, contractor) on the topic of clay plaster and finishing with Léém earth building materials. As such, we – the authors of the cooperative BC materials – have chosen to heavily « stand on the shoulders of giants »: the knowledge and guidelines come from reference works from two of the most experienced earth building communities: the French and the German community. The French network is built around the university research institution CRAterre, and spreading out towards organizations such as Cycle-terre, Amaco, ENTPE, CSTB. The German network is built around the Dachverband Lehm, with experts such as Dr.-Ing Horst Schröder, Dr.-Ing Christof Ziegert, and nation-wide regulation such as DIN norms and the EPD framework.

This Léém Clay Plasters & Paint guide is hence a compilation of the most recent research publications, technical approvals and norms in Germany and France, updated with specific extra research and experience by BC materials and Buildwise related to a Benelux context. We have tried to show as much as possible from which reference we have compiled certain specific information, by mentioning the reference in the side column in the text, and by adding the full bibliography in section 6. We are more specific in who to thank for what kind of contribution in our acknowledgement section at the end of this guide.

We hope to have made clear how this guide exists from a European spirit of sharing earth building expertise. We hope this Léém Clay Plasters & Paint will help you, and hence continue to grow the earth building sector in Benelux.

Contents

Introduction	3
1. Léém Clay Plasters & Paint for interior surfaces	9
1.1 What are Clay Plasters & Paint ?	10
1.2 Production process of Léém Clay Plasters & Paint	12
1.2.1 Secondary and primary resources	12
1.2.2 Packaging	15
1.3 Why 4 colours and 3 products?	16
1.3.1 Where do the 4 colours come from?	16
1.3.2 Which plaster should be used for which application?	17
1.4 Building standards and quality control	20
2. Properties of Léém Clay Plaster, Finish & Paint	23
2.1 Designation of Léém Clay Plaster	24
2.2 Physical properties of Léém Clay Plaster, Finish & Paint	25
2.2.1 Humidity	25
2.3 Mechanical resistance	26
2.4 Airtightness	26
2.5 Acoustic properties	26
2.5.1 Acoustic absorption	26
2.5.2 Acoustic insulation	26
2.6 Fire behaviour	27
2.6.1 Fire reaction	27
2.6.2 Fire resistance	27

3. Design guidelines	29
3.1 Field of application	30
3.1.1 Application in wet areas	30
3.1.2. Protection from splash water	31
3.1.3. Protection from cleaning water	31
3.3 Technical added value in a design	32
3.3 Typical build-up for Léém Clay Plasters & Paint	33

4. Implementation guidelines	35
4.1 Introduction to implementation	36
4.2 Layer systems for Léém Clay Plaster & Finish	38
4.3 Site conditions	38
4.4 Substrates for Léém Clay Plaster & Finish	39
4.4.1 Suitable plaster substrates	39
4.4.2 Preparing the substrate	40
4.4.3 Plaster lath materials	42
4.4.4 Primers	43
4.4.4 Summary of supports and their preparation	44
4.5 Preparation of Léém Clay Plaster & Finish	45
4.5.1 Duration of use of fresh plaster mortar	46
4.6 Application of Léém Clay Plaster & Finish	47
4.6.1 Applying the base coat	49
4.6.2 Applying the top coat	51
4.6.3 Corners	52
4.6.4 Shrinkage cracks in the base coat	53
4.6.5 Léém Flax Reinforcement Mesh	54
4.6.6 Finishing techniques for Léém Clay Plaster & Finish	56
4.6.7 Surface treatments	60

4.7 Maintenance of Léém Clay Plaster & Finish	61
4.8 Léém Clay Paint	62

5. Construction details 65

5.1 Léém Clay Plaster & Finish on masonry	66
5.2 Léém Clay Plaster & Finish on concrete	67
5.3 Léém Clay Plaster & Finish on stone wall	68
5.4 Léém Clay Plaster & Finish on earth wall	69
5.5 Léém Clay Plaster & Finish on drywall panels	70
5.6 Léém Clay Plaster & Finish on earth panels	71
5.7 Léém Clay Plaster & Finish on wood-based panels	72
5.8 Léém Clay Plaster & Finish on straw bales	73
5.9 Léém Clay Plaster & Finish on wood frame structure	74
5.10 Léém Clay Plaster & Finish on a heated wall	75

6. Bibliography 79

7. Acknowledgements and credits 81

1. Léém Clay Plasters & Paint for interior surfaces



1.1 What are Clay Plasters & Paint ?

Léém Clay Plasters & Paint can be used as plaster for internal walls and ceilings. The technique of using raw earth as a plaster or paint is a widespread vernacular technique. In the Benelux, clay plaster mainly made of local “loam” was traditionally used as an internal finishing, while on the outside lime was used to make it more weatherproof. Léém Clay Plasters & Paint can be applied to most typical surfaces, not just those made of earthen building materials.

Léém Clay Plasters & Paint are natural blends of clay, loam, sand and potentially fibres. They provide a healthy, breathable finish for internal walls and ceilings. Léém Clay Plaster can be defined as natural because it has undergone minimal processing and contains no synthetic ingredients. They are made from non-polluted, undisturbed soil from urban sites.

Léém Clay Plasters & Paint is a ready-to-use material. It only needs water to be added in an on-site mixing process to be able to use them directly. The plaster is applied in a viscous state, using a float, trowel, brush, or by projection. A wide variety of textures and visual aspects can be reached, depending on the chosen colour, granulometry and finishing technique.

Sustainable

Léém Clay plasters and Paints are amongst the most sustainable wall finishes available.

It is recyclable, reusable, and contains no toxic ingredients, VOCs (harmful chemicals released during and after application), or synthetics. Léém Clay Plasters & Paint are healthy for the planet, the indoor climate, and the occupants. More details on the circular aspects of raw earth products can be found in the Léém General Guide.

High-performance

As well as being 100% natural, Léém Clay Plasters & Paint are also highly performant. Naturally regulating relative humidity, they allow buildings to breathe while absorbing toxins and odours. Thicker layers of plaster of 1cm or more make the most of earth’s sorption properties and help improve the indoor climate by regulating humidity. They also help to passively regulate temperature, absorb sound and can easily be repaired.

Repairable

The water-soluble reversibility of its binding qualities means it can be removed at a later date without damaging the underlying surface. Since there is no chemical binding process, the removed clay plaster can be re-humidified. This process of applying-removing-reapplying can be repeated endlessly without any quality loss, which makes it a truly circular material.



© Tijs Vervecken

1.2 Production process of Léém Clay Plasters & Paint

1.2.1 Secondary and primary resources

Léém Clay Plasters & Paint are manufactured with abundant raw materials that are available in the region of Brussels and Belgium.

Secondary resources such as excavated earth and/or mineral waste streams are sourced from construction sites and temporary storage centres. These resources are free of pollution according to the legally required thresholds of OVAM Flanders and Brussel Leefmilieu, and even extra pollution markers by BC Materials. In total, 40+ parameters are checked. This secures the resources of Léém to be free of PCB, PFC, asbestos, lead, heavy metals, flame retardants, phthalates et isocyanates.

For some products, quarried primary resources such as specific clays and sands are added in the minimum necessary quantities.

Quaternary

1. Superficial formations
2. Slope silts
3. Alluvial clays
4. Alluvial sand and gravels
5. Alluvial silts

Tertiary

6. Asschian (clays and sands)
7. Ledian (sands and sandstones)
8. Bruxellien (decalcified sands, limestones and sandstones)
9. Ypresian (clayey sands and clays)
10. Landenian (sands, silts and clays)

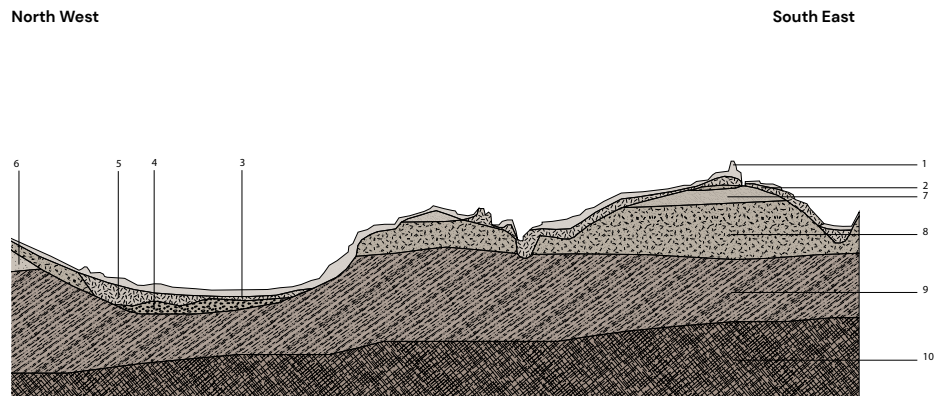

In general, a mixture of 3 types of resource is used: clay, loam, and sand. In Léém Clay Plaster specifically, no pigment nor additives are added. It is optional to add Straw Fibers. In Léém Clay Finish and Léém Clay Paint, cellulose is added. On the technical sheets of the respective products, more detailed information on the composition is presented. Here, we will introduce the 3 types of resources, and the 2 additives.



Brussels earth as a raw resource

Loam

Loam is a clayey-silty earth that can commonly be found during excavations in Brussels or Flanders. Its role is to bind and hold the product together. The local loam has a brown colour.

Clay

We also use clays from quarries. This added clay improves the binding properties of our Léém Clay Plasters & Paint and influences the colour of the final mixture.

Sand

Brusseliaan sand comes from a recycling centre in the Brussels region and has a grain size of 0-1 mm. Its role is to provide the granular skeleton and stabilise the rendering during drying to limit cracking.

In Léém Clay Plaster & Finish, we also use a river sand to give even more structure and strength.

Chopped straw

We optionally provide finely chopped straw. This comes from wheat cultivation. Wheat stalks dried in open fields are crushed and chopped to obtain a fibre for incorporation into the mix. The length of the fibre varies between 1 and 15 mm. The role of the chopped straw can be to distribute the stresses in the mixture during drying, to make the mixture lighter, and to give the plaster better resistance to mechanical stresses.

(Methyl)Cellulose

Methyl cellulose is used as an additive for the Léém Clay Paint. It enhances the adhesion of the clay paint to various surfaces, promoting good coverage and durability. It is a modified form of cellulose that is water-soluble and serves as a binder, thickening agent and adhesive. Methylcellulose is considered a relatively eco-friendly binder, as it is derived from renewable plant sources and biodegradable.

These resources are sieved, crushed and/or sun-dried by BCmaterials, then mixed according to established recipes, and finally bagged, ready for use on site.



Straw fibres as a potential addition to the Léém Clay Plaster and finish



Mixture of raw resources to create a well-balanced mixture of Léém Clay Plaster and paint



Sieving the local earth to valorise a 'waste' stream

1.2.2 Packaging

Léem Clay Plaster is available in bags of 25kg, mini-bigbags of 500kg, or bigbags of 1000kg. Bigbags come on consigned Europalets.

Léem Clay Finish is available in bags of 25kg

Léem Clay Paint is available in bags of 5kg and 25kg

All Léem Clay Plasters & Paint are labelled indicating the product, production date and colour. These bags are ready to leave for construction site. Until their use they should be stored and transported in dry conditions.

When an additive (such as chopped straw) is demanded, this will be mixed by BC materials into the product.



Léem Clay Plaster in 1000kg bigbags



Léem Clay Finish in bags of 25kg

1.3 Why 4 colours and 3 products?

1.3.1 Where do the 4 colours come from?

The offering of 4 colours creates aesthetical possibilities, for plasters, finishes and paints made from excavated earths from Belgian construction sites. All 4 colours are derived from the natural clays (and silts) which are used in the mixture. No pigments are added, the colours express the natural earth tones which are available in the region. The Brussels sand brings a cream colour, the loam a brown colour, and white, grey and red clays add their respective colour tint. See the Technical Sheets downloadable on the website www.leem.works to see the composition per type and colour of product.



1.3.2 Which plaster should be used for which application?

Léém Clay Plasters & Paint are available in three types: Léém Clay Plaster, Léém Clay Finish and Léém Clay Paint.

The difference between the three types is the granulometry, and in relation to that the application type. Léém Clay Plaster has the biggest granulometry, and is therefore suitable for the thickest layers, Léém Clay Finish is used as a thin finishing plaster, Léém Clay Paint is used as a thin brush-on layer.

a. Léém Clay Plaster

It has a granulometry of 0–2mm (DIN18947), with less than 3% of particles between 2mm and 4mm and less than 0,5% between 4 and 6mm. It is a universal plaster, commonly used as an base coat, but also suitable as a particle textured topcoat. A minimum layer thickness of 6mm is required following its granulometry. The base plaster has a medium proportion of binding agents (clay) to allow enough adhesion while still being not too susceptible to crack formation.

b. Léém Clay Finish

It is suitable for thinner or finer finishing coats. The finishing plaster has a fine granulometry of 0–1 mm and is applied as a thin skim coat on top of the base plaster. The finishing plaster is conceived for the facing layer and exhibits minimal crack formation when applied with an even and maximum thickness of 3mm. In a context where the substrate is very even, the Léém Clay Finish can also be used as base coat plaster for a further thin layer of Léém Clay Finish or Léém Clay Paint.

c. Léém Clay Paint

It is not a plaster in the true sense of the word. However, due to its plaster-like surface qualities, it can be considered as a brush-on plaster. Léém Clay Paint is available in the same colours as Léém Clay Plaster or Léém Clay Finish, and can be applied as a thin finishing with a brush. To ensure proper binding, a cellulose binding agent is used alongside clay, silt and sand. In texture, it has similarities to a lime wash.



Sample Léém Clay Paint



Sample Léém Clay Plaster



Léem Clay Plaster



Léem Clay Paint

1.4 Building standards and quality control

[1] Institut allemand de normalisation.

[2] Règles Professionels pour la mise en œuvre des enduits sur supports composés de terre crue

[3] e.V., Dachverband Lehm. Lehmbauregeln 2009. Wiesbaden

[4] Buildwise (CSTC).

There are currently no European Harmonized Standards (EN) for clay plasters, clay finishes or clay paints. However, standards for clay plasters are issued in Germany and France (DIN18947 [1] and Règles Professionels pour la mise en œuvre enduit d'argile [2]). A normative document for clay finishes and clay paints has been published by German sector organisation Dachverband Lehm (DVL TM 06) [3]. BC Materials declares the performance of Léém Clay Plaster, Léém Clay Finish and Léém Clay Paint to the German and French standards.

In Belgium, Buildwise has published a Technical Note on interior plasters based on the binders cement, lime, gypsum and clay, with conception and execution principles for the contractor (TVN/NIT 284) [4]. This technical note applies to Léém Clay Plaster and Léém Clay Finish.

Quality control of Léém Clay Plasters & Paint is executed according to DIN18947 and DVL TM 06.

These standards and accompanying standardized quality control protocol provides the security and insurability of building with Léém Clay Plasters & Paint for all of your projects.



© Adrian Deweerdt

2.

Properties of Léém Clay Plaster, Finish & Paint



2.1 Designation of Léém Clay Plaster

For complete physical properties of Léém Clay Plaster, we kindly refer to the Technical Sheets downloadable on the website www.leem.works. In this section, we will present the general classification system for plasters as proposed by the German norm DIN18947. This general classification based on physical properties results in a line of text: the designation.

Here under is the designation for Léém Clay Plaster (product code EB-CP) according to DIN 18947 :

Lehmputzmörtel (LPM) – DIN 18947 –O/2 (f/m) – S II – 1,8

Product type: LPM = Lehmputzmörtel = Clay Plaster Mortar

The referenced norm: DIN 18947.

Particle size group: For particle size group O/2mm between 85 and 99% of particles in the mortar are size 2mm or under, while between 95% and 100% are size 4mm or under. The oversize grain, in this case 4mm, shall be smaller than the minimum application thickness specified and shall comply with the limits given in DIN18947. (The Léém Clay Plaster has less than 3,5% oversize particles of 2mm-4mm, and less than 0,5% oversize particles 4mm-6mm. This means that there can be some exceptional particles up till 6mm grain size, which is the minimum application thickness.)

Fibre reinforcement/mineral:

- For clay plaster mortar with fibre reinforcement, the following additionally applies : "f" = fibre-reinforced.
- For purely mineral clay plaster mortar, the following additionally applies : "m" = mineral.

Strength class: this gives an indication of the strength of the plaster. The german norm combines minimum values of compressive strength, flexion strength, adhesive strength and abrasion. The values for Léém Clay Plaster are above the minimum values needed for strength class II, which is the strongest one.

Density class : Clay plaster mortars are divided into density classes according to the table in DIN18947 (5.5.2).

Clay plaster of gross density class 1,8 has a density between 1610 an 1800 kg/m³. Clay plaster mortar of gross density classes 0,9 to 1,2 can be designated as light clay plaster mortar.

2.2 Physical properties of Léém Clay Plaster, Finish & Paint

Following sections will give some extra information surrounding some physical properties as found on the Technical Sheets of Léém Clay Plaster, Léém Clay Finish and Léém Clay Paint.

2.2.1 Humidity

[4]] Buildwise (CSTC).

[2] Règles Professionels pour la mise en œuvre des enduits sur supports composés de terre crue

a. Water resistance

Léém Clay Plaster & Paint are not water-resistant and should therefore not be used in zones where frequent and direct water contact is possible, such as splashback area's around handwash basins, shower surfaces, etc. (However, specific splashback area's with Léém Clay Plasters & Paint can achieve water-resistance by applying a layer of waterglass or casein based fixers available in the Léém product range.)

b. Humidity regulation

In reward, Léém Clay Plasters & Paint have an excellent moisture buffer value, which especially becomes beneficial when applying bigger thicknesses. The hygroscopic and water vapour diffusion properties of clay plasters can create a buffer effect for possible fluctuations in the relative humidity of the indoor environment. To quantify this effect, some test methods have been developed, such as the Danish Nordtest. The graphic shows the moisture buffer values (MBV) of mineral plasters based on the available data (WTCB test results). These clearly show the good to excellent regulating properties of clay plasters. [4]

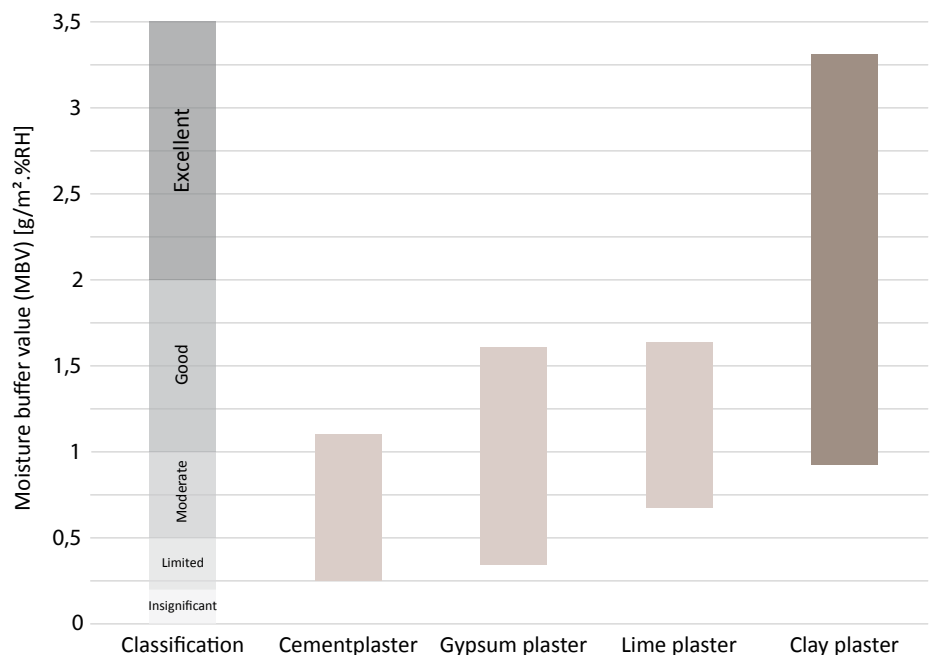

Moisture buffer value of clay plaster [4]

2.3 Mechanical resistance

The mechanical resistance for Léém Clay Plaster & Finish is defined by parameters of compressive resistance, adhesion force, abrasion resistance and impact resistance. Generally these values give a good indication of the use as interior plasters, replacing lime plasters and gypsum plasters.

The first three factors are indicated in the strength class, defined by DIN18947.

The impact resistance is defined by EN520, the European norm for gypsum board. The impact resistance of Léém Clay Plaster & Finish lies in a similar range as gypsum board.

The mechanical resistance for Léém Clay Paint is defined solely by the parameter abrasion resistance.

2.4 Airtightness

[4] Buildwise (CSTC)

[5] Earth Building Practice: Planning - Design - Building.

Airtightness can be assured by using Léém Clay Plaster in a thickness of minimum 10mm, as advised by Buildwise in NIT 284, and this guarantees the airtightness of Léém masonry wall surfaces and corners [4]. However, according to the publication Earth Building Practice [5] (p.89), earth plasters can be seen as airtight when they are continuous and do not exhibit any cracks, with the exception of very fine hairline cracks smaller or equal to 0.2mm.

2.5 Acoustic properties

2.5.1 Acoustic absorption

Léém Clay Plasters & Finishes are microporous and can be finished with a rough texture. These two factors provide good acoustic absorption up to 4 times better than gypsum plaster (NRC value mentioned in [6]). The rougher a Léém Clay Plaster gets finished, the better the absorption capacity. A wall that gets finished with a rough sponging technique will therefore absorb more than a polished wall.

[6] American Clay: Technical information. American Clay.

2.5.2 Acoustic insulation

As from 3cm of Léém Clay Plaster, the sound transmission will significantly decrease and hence acoustical insulation will increase with the thickness of the plaster. Clay plaster is a mass material, at a thickness of 10mm, you're adding a weight of 17kg for each square meter of wall. The more mass you're adding the less sound will transmit.

The airtightness of Léém Clay Plaster will also eliminate acoustic leaks in the acoustic wall build-up, which increases acoustic performance of the wall.

2.6 Fire behaviour

[5] Earth Building Practice: Planning - Design - Building.

2.6.1 Fire reaction

Clay plaster without fibrous additives are classified as the equivalent of non-flammable, class A1 according to NBN EN 13501-1:2019. Léém Clay Plasters & Paint is standardly delivered without fibres and is therefore a non-flammable building material.

When earth mixtures contain organic additives, they are still classified as non-combustible when the proportion of homogeneously distributed organic materials constitutes no more than 1% of the mass or volume (whichever is larger) according to DIN18947.

The Léém Clay Plaster can optionally be delivered with additional straw fibres. These are 1% of the total mass, and therefor the Léém Clay Plaster with fibres is still considered as non-flammable (A1).

[5] (p.90)

2.6.2 Fire resistance

The crystallized water content is relevant for determining the fired resistance. Earth contains comparable amounts of crystallized water content to gypsum. Moreover, when exposed to fire, its structure does not disintegrate but actually becomes harder by forming ceramic structures. The mechanical adhesion of the plaster to the underlying surface is affected through fire behaviour. However it can be ensured, for example, through the use of a plaster lath system (see section 4.4.3).

[5] (p.90)

3.

Design guidelines



3.1 Field of application

Léém Clay Plasters, Finishes and Paints are ideal to finish walls and ceilings in dry indoor spaces.

As a first step, walls and ceilings can be covered with Léém Clay Plaster to flatten irregular walls. As a subsequent finishing, Léém Clay Finish and Léém Clay Paint (and even Léém Clay Plaster in a second coat) provide a unique aesthetic with a depth and texture not found in conventional wall finishes. With this aesthetical quality they can be used to create an attractive indoor finishing, either as a unified interior finishing or on an accent wall. The texture and colour can vary depending on the desired atmosphere. In exceptional cases, it can be used for outdoor use, provided proper protection from rain, snow and hail is ensured.

3.1.1 Application in wet areas

[5] Earth Building Practice: Planning - Design - Building

Léém Clay Plasters & Paint are used in living areas and similar kinds of interiors. It is important, to take into account their susceptibility to moisture. Léém Clay Plasters & Paint are generally suitable for temporarily wet area's such as kitchens and bathrooms. For wet rooms subject to continuously high levels of humidity, such as swimming pools or industrial kitchens, clay plasters are not suitable. In such cases surfaces are required to be easy to clean.

Léém Clay Plasters & Paints can be used in cellars provided the walls are dry.

Léém Clay Plasters & Paints can generally only be used on surfaces protected against the effects of weather. Therefore, we do not recommend using it in outdoor areas. However, when protected from direct water contact (no contact with driving rain or splashback water), it is possible to use Léém Clay Plasters outside.

[5]



A distance of 5cm is kept between the floor and the Léém Clay Plaster

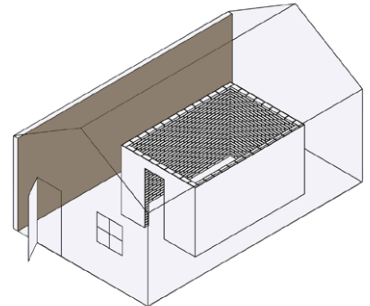
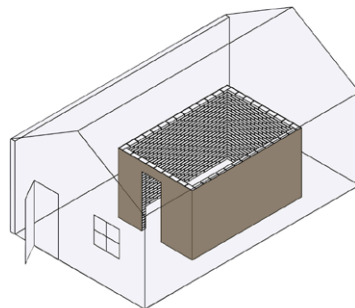

Léém Clay Plaster are generally applied in interior context

3.1.2. Protection from splash water

At a splashback surface behind a sink or cooking plate, Léém Clay Plasters & Paint should not be left exposed. It is preferred to design in a way that on these zones a more appropriate material is applied, one that is waterproof or easy to wash off, such as tiles.

In local cases, a protection can be applied on the exposed Léém surface, such as a universal fixation product (waterglass or casein based fixers available in the Léém product range). It is advised to only use such protection locally, since it hinders the hygroscopic behaviour of the material. Another downside of such fixation is that the surface can not be reworked.



Léém Clay Plaster Red with fixative against splash water

3.1.3. Protection from cleaning water

To prevent Léém Clay Plasters & Paint from soaking up water, sufficient distance must be maintained between the floor finishing level and the lower edge of the plaster or paint in areas where there is heavy water cleaning.

3.3 Technical added value in a design

[7] Urbane eco, sustainable building solutions

Applied at the right places and with the right thickness, Léém Clay Plaster can provide a technical added value on top of its aesthetical value. It can provide:

- Moisture regulation, for example in a bathroom. A high amount of Léém Clay Plaster can buffer the air humidity during a shower.
- Temperature regulation, for example in a lightweight construction. By adding mass the temperature will stay more stable through the principle of thermal inertia.
- A reduced acoustic transmission, for example between two bedrooms.
- An airtight layer, for example on the interior side of an exterior wall.

Léém Clay Plaster, Finish & Paint are 'breathing' materials, which means they have a low water vapour diffusion resistance (See General Guide section 2.2.3) and are hence vapour permeable. As a general design guideline, it is advised to combine with underlying wall build-ups that are also «breathing», or vapour permeable. Where possible, it should be avoided to put a vapour barrier such as a cement plaster or certain primers. Small incidents of high relative humidity which are blocked by vapour barriers can cause considerable damage to structures and human health through the development of mould and bacteria. High moisture levels also affect building performance. So to counteract this from happening, buildings which are built with vapour open materials will help transport excess moisture away from the indoor environment, thereby ensuring the long term health of the building fabric. Using materials which absorb and release water as vapour (known as hygroscopicity), and as liquid (known as capillarity) is important when building a «breathing» home.

On top of being vapour permeable, Léém Clay Plaster has the ability to regulate humidity, by absorbing and releasing water as a gas. This way it will help to stabilise indoor air humidity, reduce surface condensation and keep other building elements dry (such as wood). The benefits of these properties for humidity control and ventilation in buildings are considerable.

[7]



A Léém Clay Finish Red in a kitchen area (on top). At the splashback zone a cream Léém Finish with added waterproof casein layer (available in the Léém product range) has been applied.

3.3 Typical build-up for Léém Clay Plasters & Paint

To apply Léém Clay Plaster, a wall or ceiling should be foreseen that is clean, dry and free of dust. They should also be structurally sound and capable of carrying the applied weight. Existing or new masonry are great substrates, they can typically be used directly as a support for the Léém Clay Plaster. Also other substrates such as drywall or clay panels, existing plaster, etc. can be used as a support. Have a look at section 4.4 and 5 for detailed information on this. Sometimes a primer is applied to prepare the substrate.

A typical wall covered with Léém Clay Plasters & Paint is built up from two layers.

First a base coat is applied; the base coat rectifies and homogenises the surface to be plastered. It does not remain visible but is intended to receive one or more finishing coats. Base plaster can also incorporate technical installations such as cables, ducts or heating pipes. The base coat can be between 6 and 15mm thick. (see section 4.6.1)

Secondly, a top coat is applied over the previously dried base coat. This top coat can be applied with the Léém Clay plaster or Léém Clay Finish. It creates one homogenous finishing layer, and defines the final colour and texture of the wall or ceiling. The top coat can be from 3 to 6 mm thick, depending if Léém Clay Plaster or Léém Clay Finish is used. (see section 4.6.2)

Optionally, a surface treatment can be applied on top of the finishing layer. For example if another colour is desired, a clay paint can be used, if a protected surface is desired, a fixative can be applied.

- 1: Adhesion coat or primer (optional, depending on the substrate)
- 2: Base coat (Léém Clay Plaster)
- 3: Léém Flax Reinforcement Mesh (optional, depending on the substrate)
- 4: Finishing layer (Léém Clay Plaster or Léém Clay Finish)
- 5: Surface treatment (optional, e.g. Léém Clay Paint)

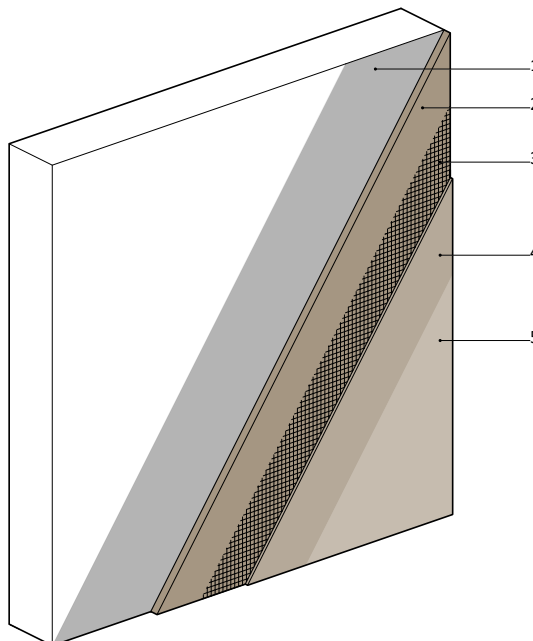

General scheme of a typical clay plaster build-up

4.

Implementation guidelines



4.1 Introduction to implementation

In this section, we'll provide guidelines on the implementation of Léém Clay Plaster and Léém Clay Finish (Section 4.2 until 4.7) and for Léém Clay Paint (Section 4.8).

We will talk about the site preparation, the preparation of the substrate, the preparation of the mixture, the application of the mixture and the maintenance.

To successfully apply Léém Clay Plaster, Finish & Paint and achieve optimal results, the required skills and tools closely resemble those necessary for working with other types of plaster or paint systems. If a craftsman is already familiar with applying gypsum or lime plaster, they possess a foundation of techniques that are highly applicable to working with Léém Clay Plaster & Finish. It is similar for professional painters and Léém Clay Paint. However, it's important to note that specific focus should be placed on two key aspects: the drying times and the finishing technique.

When it comes to drying times, understanding the unique characteristics of Léém Clay Plaster and Léém Clay Finish is essential. Unlike gypsum plaster, clay plaster tends to dry more gradually and can be influenced by factors such as humidity and temperature. As a result, craftsmen should be prepared to adapt their timing and expectations to ensure the plaster sets properly and achieves the desired finish.

Additionally, the finishing technique deserves special attention. While the basic application gestures may align with those used in gypsum and lime plastering, achieving the desired aesthetic and functional outcome with Léém Clay Plaster and Léém Clay finish may involve slight adjustments. The texture and final appearance can differ from gypsum plaster, so craftsmen should practice and refine their finishing techniques to achieve a harmonious and consistent result.

One notable advantage of Léém Clay Plaster & Finish is its popularity among DIY builders, owing to its forgiving and repairable nature. After it dries, the plaster remains reworkable when re-humidified, allowing for adjustments even after the initial application. This characteristic offers a level of flexibility and ease that DIY builders find highly advantageous, as it enables them to achieve the desired result through experimentation and fine-tuning, even after the initial plaster application.



4.2 Layer systems for Léém Clay Plaster & Finish

[5] Earth Building Practice: Planning – Design – Building.

The selection of an appropriate plaster system depends on the substrate to be plastered and the desired surface quality. Other specific contributory factors include the degree of thermal fluctuation or the need to incorporate a Léém Flax Reinforcement Mesh. The plaster system influences the choice of granularity and vice versa. The rules are similar to those of plasters with mineral binding agents, for example lime plaster. As a rule, topcoat plasters should not be stiffer than base coat plasters, or else even slight deformations or thermal stresses in the base coat will lead to the surface flaking.

Léém Clay Plaster is coarse-grained (includes particles until 4mm) and is suitable for thicker coats of approximately 6–15 mm, in some cases as much as 35 mm (when adding fibres).

Léém Clay Finish is fine-grained (particles until 1 mm) and is suitable for coats of up to 3 mm.

Single coat clay plasters are possible in some specific cases. They require a sufficiently flat substrate with even absorbency properties. Surfaces that do not absorb evenly cause the plaster to dry unevenly which usually then becomes evident when the surface is worked.

A compromise between single and multi-coat plaster systems is to work over a thin preparatory levelling coat. These can be used to even out surface irregularities and lend the substrate more even suction characteristics.

High-quality surfaces are best realised using a multi-coat plaster system. Earth base coat plasters usually serve as an excellent base for earth topcoat of finishing layers.

[5] (p. 59)

4.3 Site conditions

In terms of **climate conditions**, a minimum temperature of 5°C is advised. Do not render if there is a risk of frost. Above 30°C or in dry winds, it is advisable to slightly rewet the rendering by spraying with water in the days following application, or to hang wet cloth in front of it without touching the wall, or any other measure to avoid drying out too quickly.

The Léém Clay Plaster bags should be **stored away from rain and damp**. Big bags and sacks can be stored outside under a tarpaulin and lifted off the ground by a pallet. If these conditions are met, the plaster can be stored for an unlimited period.

4.4 Substrates for Léém Clay Plaster & Finish

4.4.1 Suitable plaster substrates

As for all paints and plasters, **substrates for Léém Clay Plasters & Finish need to be firm, rough, sufficiently absorbent and dry**. Loose sections should be removed or stabilized. The substrate should be free of multilayer paint coats and must not be contaminated with oils and salts (which are most likely to collect in the wall sections above stem walls which experience moisture penetration). Depending on the uniformity of finish desired, they should be sufficiently smooth and level. For plaster applications on ceilings, the required mechanical properties of the substrate are greater than that of the walls.

Suitable substrates to receive Léém Clay Plasters & Finish:

- Existing and sufficiently stable clay, lime, gypsum, and cement plasters
- Masonry, it is well textured and absorbs well (see section 5.1)
- Concrete (see section 5.2)
- Stone wall (see section 5.3)
- Monolithic earth wall (see section 5.4)
- Drywall panels (see section 5.5)
- Clay panels (see section 5.6)
- Wood-based panels, covered with reed mat or other lath (see section 5.7)
- Straw bales (see section 5.8)
- Wood frame structure, covered with reed mat or other lath (see section 5.9)



Examples of Léém Clay Plaster on suitable substrates: Léém Compressed Block, hempcrete block and gypsum fibre board (Fermacell)

4.4.2 Preparing the substrate

The **required strength of the substrate** for Léém Clay Plaster is no greater than for other plaster. As clay plasters form a comparatively soft and low-stress layer, they can also be applied to very soft mineral substrates. Loose or flaky stone or plaster remains must be removed. Loose means that they can be removed by hand without great effort. Sandy constituents should be brushed off; where old plasters are sandy, they may need stabilising. Coats of paint can only remain on the substrate if they are absolutely stable. If the substrate consists of building boards, these must be sufficiently level and arranged in bond. They should not give in under pressure: pressing with one's thumb provides sufficient indication of stability.

Sufficient **surface roughness** or texture is a comparatively important criterion as clay plaster adheres mechanically. Thick applications and applications subject to specific stresses, such as those containing embedded wall heating, adhere better on substrates with rougher surfaces. The method of application can also have a decisive effect: a preparatory spray or slurry coat with a rather liquid Léém Clay Plaster can improve adhesion.

For the plaster to adhere properly, sufficient **absorbency** – i.e. good suction characteristics – is likewise important. A lack of surface absorbency can be compensated for with surface roughness to a limited degree and vice versa. For this reason, granular and highly adhesive primers are used to prepare some low-suction surfaces for plastering.

Only sufficiently **dry substrates** will be absorbent. If the pores are filled with water the surface will not absorb any more moisture. This is why when pre-wetting surfaces they should not be saturated with water but wetted with a fine spray mist. Particular attention should be paid to massive wall constructions that have been exposed to rain for a prolonged period where the pores are partially or fully saturated with water. In most cases, visual assessment is sufficient to establish if previous wet earth constructions (rammed earth, light earth) are dry enough to plaster over, but if in doubt, the moisture content can be ascertained more precisely by oven-drying a test sample and comparing the relative weight before and after. In addition to the aforementioned mechanical aspects, wet substrates can hinder the drying out of clay plasters considerably and possibly lead to damages.

Substrates that are not absorbent but sufficiently rough such as wood-wool insulation board or reed mat insulation boards should not be wetted as the water then acts as a separating film.

Surfaces that are not rough or not absorbent can lead to increased crack formation in the earth plaster. In such cases the lack of adhesion to the substrate means that the background surface does not help in resisting plaster shrinkage. Where the plaster otherwise forms many small cracks and insignificant shrinkage cracks, here shrinkage results in fewer but larger cracks.

The requirement that substrates be **free of contaminants** (for example shuttering release agents) **and dust** is no different to when using other plaster mortars. Substrates with tar, nicotine or soot stains, for example around chimney breasts, must either be replaced or contained using the painter's usual product, or else they will show through the plaster. The Léém product range provides such a containing product.

Particular attention should be paid to possible **salt contamination** in the substrate. Here it is worth noting that the moisture sorption characteristics of clay plasters are sometimes confused with the properties of special restoration plasters. Soluble salts transported with moisture in masonry damage mortar by expanding in volume as they crystallise. Restoration plasters are designed to have a coarse pore structure that provides sufficient space for salt crystals to expand within it. They are hydrophobic and have a rigid, cement-based mineral binding matrix. Clay plasters, like lime and gypsum plasters, do not have these qualities. Their pore structure is not as open and the binding effect of the clay minerals comparatively weak. For those reasons, clay plasters are even used as «sacrificial plaster layers» with the aim of desalinating a wall: after they have absorbed soluble salts, they can easily be removed.

Salt contamination is often not visible with the naked eye and when in doubt an analysis must be conducted. Common situations include old brickwork walls that stand directly on moist ground. Léém Clay Plaster & Finish is, however, suitable as a topcoat for restoration plasters due to their high vapour permeability.

[5] (pp. 43-45)

1. On a solid base, the plaster can be placed directly on a cleaned and humidified wall
2. On panels or a non-homogeneous support, a plaster lath is typically recommended
3. On a flat surface, a textured primer is needed

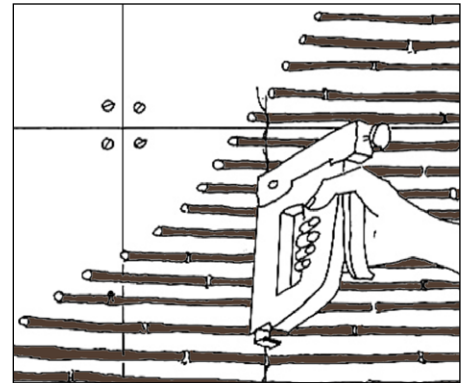
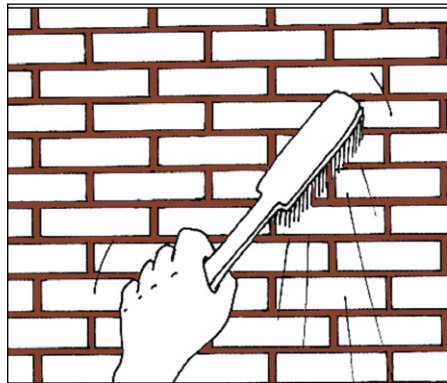

[8] Cycle Terre. Guide de conception et de construction.

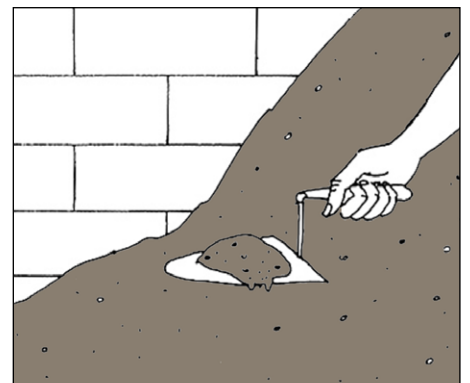
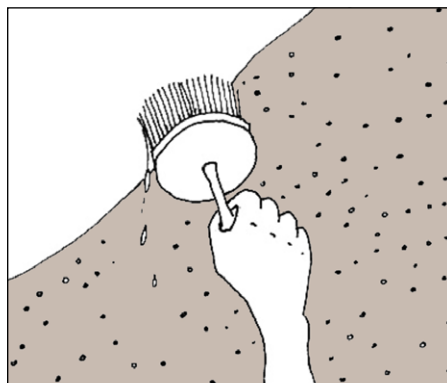

Illustration of main steps to prepare a substrate [8]

- [9] Sustainable Building with Earth.
[8] Cycle Terre. Guide de conception et de construction.
[5] Earth Building Practice: Planning -

4.4.3 Plaster lath materials

Plaster laths provide a largely independent mechanical key for plastering substrates with little own surface adhesion, for example wooden composite surfaces such as OSB. They need to be fixed durably and sufficiently often so that they are not or only very slightly springy. As a rule, sufficiently wide-meshed products should be used, appropriate for the planned granularity of the plaster mortar. Only then can the plaster mortar penetrate the mesh and ensure good contact with the substrate. It is imperative that the plaster lath does not cause hollows to form behind the plaster layer.

Reed lath is the most common lath used in earth building. It should not be prewetted before plastering and the plaster should be applied in two coats. Embedding Léém Flax Reinforcement Mesh across the entire surface of the base coat is recommended.

Reed mats can be used to cover building elements made of wood or wooden composites, or as permanent formwork. The individual reeds are bound together on both ends with a 1-mm-thick non-corrosive binding wire. This keeps the reeds fixed in place, allowing them to be rolled up as a mat. Such reed plaster mats are commonly available in ecological building stores. They should not be confused with the one sold at garden stores, since these often do not meet the needed requirements.

Reed panels serve as both plaster lath and thermal insulation. Standard panels are 20 or 50 mm thick and their dimensions are 2 × 1 m. The panels have non-corrosive binding wires across the reeds spaced approx. every 20 cm which are stapled every 5 cm.

Other lath materials such as brick-wire mesh or metal lath can also be used to improve the earth plaster's adhesion to the substrate.

Finally, plaster laths should not be confused with reinforcement mesh. The latter serve to bridge joints between building boards or to resist stresses occurring in the upper third of the plaster thickness. (see section 4.6.5)

[9], [8] p49



Reed lath stapled on OSB panels at project Karper, Brussels

4.4.4 Primers

Primers are used to prime surfaces in preparation for receiving clay plasters:

- to even out irregular suction characteristics
- to protect underlying surfaces from absorbing excess moisture
- to create a better adhesion of the plaster to the surface
- when made coarse, to improve the surface roughness, so that the clay plaster can mechanically attach better to the surface.

Primers used for clay plaster are preferably water vapour permeable. If this is not the case, the potential hygroscopic function of the underlying wall is lost.

Due to the special characteristics of clay-bonded building materials of Léém, primers are generally not required. To increase working time, in all but a few special cases it is generally sufficient to moderately pre-wet the surface. For earth substrates, this improves the adhesion between the plaster and the substrate.

Léém offers a sodium silicate-based primer that is textured, water vapour permeable and has a neutral odour. Alternatively, silicate paints can be adapted by adding coarse sand to create a self-made primer.

[5] (p. 49)



An existing gypsum substrate prepared with structured primer to allow the Léém Clay Plaster to properly anchor on the wall

4.4.4 Summary of supports and their preparation

[9] Sustainable Building with Earth.

This table sums up the substrates with an overview of key aspects how to prepare the substrates before applying the Léém Clay Plaster.
[9]

Substrate	Preparation			
	Primer	Spray or slurry coat	Lath	Pre-wetting
Masonry				
Léém earth blocks (moulded or compressed)				✓
Extruded earth blocks		✓		✓
Fired earth bricks				✓
Clinker bricks		✓		
Sand-lime blocks				✓
Concrete blocks or AAC blocks	✓			✓
Concrete				
	✓			
Natural stone				
		✓		✓
Monolithic earth wall				
Rammed earth				✓
Light earth / half-timber framing				✓
Cob				✓
Existing plaster				
Earth plaster				✓
Lime or gypsum plaster	✓	✓		
Drywall panels				
Gypsum(fibre) panels	(✓)		(✓)	
Clay panels				✓
Woodwool panels / reed panels		✓		
Wood composite panels				
			✓	
Fibres				
Straw		✓		✓
Hempcrete				✓

4.5 Preparation of Léém Clay Plaster & Finish

Léém Clay Plasters & Finish are available as a slightly humid or dry mixture. We recommend to use batches of the same production dates to avoid possible colour differences.

Mix the product with water until you obtain a smooth, homogeneous paste that is pleasant to work with. Typically 20%–25% of water should be added for Léém Clay Plasters. A Léém Clay Plaster applied by machine should be more wet than if applied manually. Mixing time is 6 to 15 minutes.

Mixing can be carried out with all kinds of concrete mixers, including a mixer integrated into a plastering machine. For small quantities, a painter's mixer, a mixing attachment on a drill or hand mixing (trowel) are possible.

For a more homogeneous, creamier coating mix with optimum performance, it is best to leave the mixture to settle for at least half an hour, and subsequently remix.



Preparation of Léém Clay Plaster

4.5.1 Duration of use of fresh plaster mortar

[8] Cycle Terre. Guide de conception et de construction.

Plaster without plant fibres

Once mixed, the plaster mortar can be used indefinitely as, in the absence of added cement, plaster or lime, it does not set hydraulically. As soon as the mixture becomes too dry, simply re-wet it to continue working. Once dry, the plaster can be rehydrated and reused. However, the corrosive effect on machinery and equipment must be taken into account.

Plaster with plant fibres

After a few days resting as mix, the plant fibres can begin to deteriorate without affecting the technical qualities of the rendering. However, a change in colour or odour is possible. This phenomenon is accelerated by an increase in ambient temperature.

[8]



Clay plaster with a large amount of straw fibre

4.6 Application of Léém Clay Plaster & Finish

[5] Earth Building Practice: Planning - Design - Building.

Léém Clay Plaster & Finish can be spread, thrown or sprayed. Thick plasters adhere better when thrown rather than spread. On construction sites, the majority of Léém Clay Plaster as base coat is applied by machine for an efficient application process. The viscous plaster mixture is pumped from the machine in hoses by a screw or piston pump and propelled through a spray applicator with compressed air. Spray-applied plaster adheres better than hand-applied plaster.

Examples of machines that can project clay plaster are G4, G5, MP25, S28, P13, S5 & S30,...

However, Léém Clay Plaster can also be spread without any problems, especially for smaller spaces and DIY projects.

Unlike other plasters, Léém Clay Plaster & Finish can remain in the hoses and machinery overnight or over the weekend because they are water soluble and do not cure. Clean surplus plaster does not need to be disposed of but can be reprocessed for later use. Although clay plasters are water soluble it is still necessary to protect other building elements and equipment against soiling. Porous surfaces in particular, such as light-coloured woods, are susceptible to staining if clay plaster is allowed to soak into their pores.

[5] (p. 61)



Scaffolding for manual application of Léém Clay Plaster



Manual tools for application



Léem Clay plaster applied manually with a trowel



Léem Clay plaster applied with a spraying machine



Léem Clay plaster applied with a spraying machine on reed lath, strawbale and masonry

4.6.1 Applying the base coat

A base coat in Léém Clay Plaster is a layer that rectifies and homogenises the surface to be plastered. It does not remain visible but is intended to receive one or more top coats of Léém Clay Plaster and/or Finish. This base coat can also incorporate technical installations such as cables, ducts or heating pipes.

Thickness:

From 6 to 15 mm, greater thicknesses are possible by applying the coating in several passes.

Installation:

- Prepare the substrate and dampen absorbent substrates.
- Apply Léém Clay Plaster by hand using a trowel, or float, or spray by machine over the entire surface until the desired thickness is achieved.
- The surface is levelled with a plasterer's ruler or with a spack(le) knife tool of a size suited to the surface to be treated, to obtain a sufficiently flat surface.
- If the base coat will receive a second layer of Léém Clay Plaster, texture it with a toothed float trowel to improve adhesion. If it will receive Léém Clay Finish as a top coat, leave it rough, without smoothing or texturing it.



Léém Clay Plaster Brown as a basecoat in rough texture,
Léém Clay Plaster Red as a toplayer

A base coat should be applied to a clean substrate, which has been brushed if necessary. Conventional masonry or plastering tools are used. If corner strips or other profiles are used, they should be fixed beforehand.

Where the surface to be plastered is very irregular, hollows and cracks can be filled with plaster material when preparing the substrate. When these areas have dried slightly, the base coat in Léém Clay Plaster is applied over the entire surface. Where excessively deep unevenness requires large thicknesses of mortar, masoned fillings are preferred.

The base coat must be completely dry before applying a top coat. Léém Clay plaster & Finish does not set like cement, but hardens as it air dries. It is therefore necessary to ensure that the water inside a freshly applied base coat can evaporate on site. Temperatures above 10°C and good air circulation are recommended.

Once Léém Clay Plaster is dry, fine hair cracks, millimetre in size, are tolerated. However, Léém Clay Plaster must adhere perfectly to the substrate and the cracks must not cause the plaster to come off in pieces.

Drying time:

Approximately one week per 10mm of thickness under normal circumstances (+20°C and 60% relative humidity). This time may vary according to ventilation and temperature conditions.

If the temperature is too low or ventilation is poor, it is possible to use an artificial drying method. This solution is particularly recommended for plasters that incorporate organic fibres to prevent the appearance of mould.

[8]



Levelling the surface of the Léém Plaster with a smoothing trowel

4.6.2 Applying the top coat

The top coat can be applied with the Léém Clay Plaster or the Léém Clay Finish.

The top coat is applied over the previously dried base coat in Léém Clay Plaster. It thus covers any cracks that may have appeared in the base plaster, and allows the final colour of the wall to be varied and with the desired texture.

Thickness:

from 3 to 6 mm, depending if the Léém Clay Plaster (6mm) or the Léém Clay Finish (3mm) is used.

Application

1. Moisten the base coat.
2. Apply the top coat to the entire surface using conventional plastering or masonry tools (manually with a trowel, float or float blade, or by machine in a thin layer until the desired thickness is obtained).
3. The surface is levelled with a smoothing trowel sized to match the surface to be treated.
4. When the rendering has begun to «pull» (to dry), it is worked with a float or sponge float, and possibly a smoothing trowel, to obtain the desired texture.
5. Make earth/wood, wall/ceiling and wall/wall joints.

Drying time:

24 to 48 hours with proper ventilation and temperature.

[8]



Different steps of plaster application

4.6.3 Corners

Special care must be taken when finishing corners to ensure good mechanical resistance and the desired aesthetic effect. Corners should be conceived before plastering.

Outgoing corners:

Outgoing corners are fragile. It is preferable to round them. Otherwise, they need to be reinforced by non-corrosive corner profiles, as shown below.

Straight angles:

To obtain a perfectly straight corner, you can:

- Embed an L-shaped metal or plastic profile. Léém Clay Plaster or Finish then butts up against it. When laying the base coat, you need to allow for the thickness of the top coat.
- Make a right angle with lime-plaster mortar (proportions: 1 part air lime to 2 parts sand and 3 parts plaster) in continuity with the Léém Clay Plaster or Finish. (Mind the potential colour differences.)

Rounded corners:

- For a rounded corner with a slight curvature, use corner trowels (vertical movement).
- A float (horizontal movement) is used for a more pronounced curvature.
- Templates can be used for steeper or truncated corners. It is advisable to create a chamfer on the wall, otherwise too great a thickness of plaster will be required.

Recessed corners:

- Straight: use a normal trowel to smooth one wall after the other.
- Rounded: use a corner trowel with a more or less pronounced curve or a template such as a PVC tube.

[8]

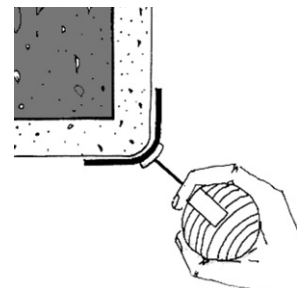
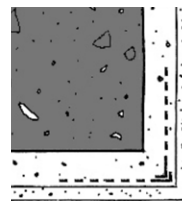
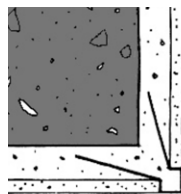

Galva Profile for a straight and reinforced outgoing corner

Plastic profile embedded in base coat

Trowel to shape rounded outgoing corners

4.6.4 Shrinkage cracks in the base coat

The base coat of Léém Clay Plaster should adhere well and provide a sufficiently stable base for subsequent plaster layers. As a result of the thickness that is typically applied, this basecoat has a greater tendency to form cracks than topcoat plasters. Smaller shrinkage cracks are not a problem for the adhesion of subsequent plaster layers. Large shrinkage cracks, however, can result in the base coat losing partial mechanical adhesion to the substrate causing it to separate into patches that rise slightly at their edges.

The degree of adhesion can be tested manually by applying thumb pressure to the edge of the crack. Loose particles should be removed and the cracks closed with Léém Clay Plaster before further plastering. Large shrinkage cracks otherwise show through to the top coat.

Reasons for excessive shrinkage cracking include:

- Too thick layers
- Mortars prepared with too much water
- Sandy, low suction or very smooth substrates
- Too rapid drying and/or low suction of the substrate
- Very high suction substrates

Before further plastering of the surface, the base coat must be allowed to dry to the extent that no further formation takes place. Crack formation in the base coat after it has been plastered over results in cracking in the top coat.

[5] (pp. 59-60)



Shrinkage cracks appearing in base coats

4.6.5 Léém Flax Reinforcement Mesh

Unlike plaster laths, reinforcement fabric does not help the plaster adhere to the substrate. Its purpose is to resist tensile stresses within the surface of the plaster. Léém Flax Reinforcement Mesh help to reduce the degree of cracking to a tolerable level. While it is not possible to categorically avoid cracks forming, Léém Flax Reinforcement Mesh minimise the risk.

The decision whether or not to use Léém Flax Reinforcement Mesh with Léém Clay Plaster follows these typical cases:

- Irregular substrates that behave differently across their surface (for example: changes of material, hollow boxes for roller shutters, concrete lintels and ring beams)
- Soft substrates (for example: light earth, wood fibre insulation boards, reed mat insulation boards, straw bales)
- Surfaces that are subject to impact loads and vibrations (for example: the underside of timber ceiling joists).
- Shear stresses that occur around openings for windows and doors.

It should be clear that Léém Flax Reinforcement Mesh is notable to resist more serious movement such as building settlement or deformations in the building's structural framework. In old buildings one should carefully consider whether it is worthwhile embedding Léém Flax Reinforcement Mesh in the plaster. In extreme cases, the presence of the mesh may mean that damages affect an entire surface whereas without reinforcement fabric smaller cracks might have formed.

As with other plaster systems, Léém Flax Reinforcement Mesh should be placed 2/3 of the plaster thickness away from the plaster base, i.e. just beneath the surface. In the case of two-coat plasters, the Léém Flax Reinforcement Mesh is embedded in the surface of the base coat layer.



Léém Flax Reinforcement Mesh embedded in the base coat, covering the lintel

Léém Flax Reinforcement Mesh is laid directly onto the wet layer of plaster and carefully worked in with a felted or wooden float. The mesh must lie flat and taut and be free of creases. Laying the mesh onto dry substrates is not advisable as insufficient wet plaster is then able to penetrate it; in such cases the mesh ends up being a separating layer that impairs the connection between the topcoat and base coat plaster.

Individual strips of Léém Flax Reinforcement Mesh should be overlapped by at least 10 cm when applied to the whole surface. The overlap must be carefully worked to avoid the double layer acting as separating layer. The mesh should extend into neighbouring areas beyond the area to be reinforced by another 25 cm.

[5] (p.61)



Léém Flax Reinforcement Mesh embedded in the base coat

4.6.6 Finishing techniques for Léém Clay Plaster & Finish

a. Surface appearance

The surface appearance of the rendering depends on the degree of drying at the time of finishing and the tools used. Here is an overview of different finishing techniques, the moment and the resulting effect. In Belgium, sponging is currently the most common finishing technique which delivers a homogenous surface.

• Sponging

Tool: a sponge or sponge float
Moment of application: early, when the plaster is still soft or late, when the plaster has hardened and is drying
Result: homogeneous surface, grains and fibres stick out

• General polishing

Tool: polishing trowel
Moment of application: Briefly after the application, when the plaster is still soft
Result: ribbed structure

• Fine polishing

Tool: metal or plastic Japanese trowel
Moment of application: extra polishing action after general polishing. One can continue smoothening, sometimes by humidifying
Result: Very smooth and shiny surface

• Float

Tool: wood or plastic float board
Moment: after levelign the surface
Result: a well densified surface.
with rough float: fine rubbing marks
with smooth float: homogeneous surface

• Brushing

Tool: big brush
Moment of application: Briefly after the application, when the plaster is still soft
Result: ribbed structure

[8]

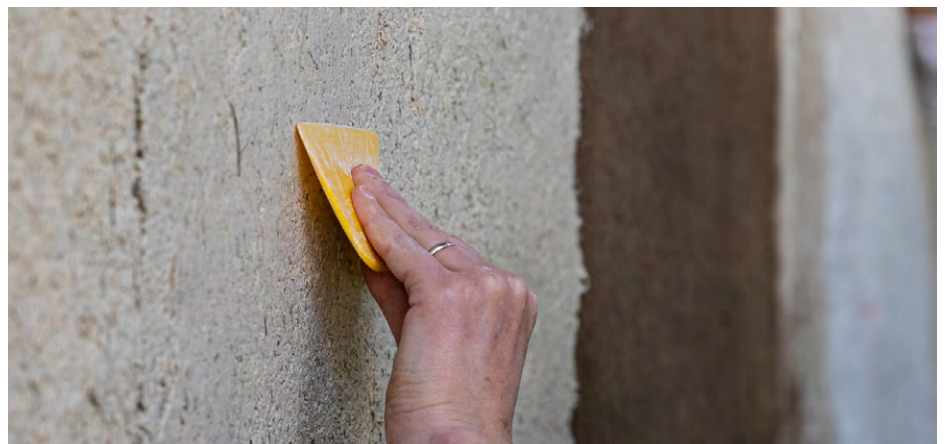

Refined finishing using a plastic flexible trowel allows to reach a polished smooth surface



Sponging the Léém Clay Finish with a sponge float



Using a plastic flexible trowel allows to reach a polished smooth surface



Using a wood float results in a well densified surface



Final result of a smoothly polished Léém Clay Finish



Pronounced texture of a rough wood float



Léém Clay Plaster with a high quantity of additional straw fibres



Natural sand present in the Léém Clay Plaster becomes visible as a result of excessive sponging



Sponging results into a homogenous surface. For Léém Clay Plaster, which has a bigger granulometry, gravels may become more visible depending on the moment and intensity of sponging

[8] Cycle Terre. Guide de conception et de construction.

b. Brushing and other final actions

Léém Clay Plaster has the biggest particle size. Especially when sponged but also when polished or floated, a Léém Clay Plaster surface contains loose sand particles after having totally dried. A final step is hence to sweep the entire surface of the wall with a brush to take of the loose particles of sand, then wipe it with a slightly damp sponge to take off the last few smaller loose particles. .

If slight cracking appears as the product dries, re-wet a fairly large area of the surface to be worked, then smooth the coating with a sponge.

Because Léém Clay Plaster does not contain the additive cellulose (see section 1.2.1), a slight dusting might be noticed on a finger after rubbing this finger on the surface. This is normal. If this needs to be prevented, the fixative surface treatment (see section 4.6.7) can fix the dusting so as to have no effect at all after rubbing the surface.

[8]



Léém Clay Plaster finely sponged in the office building of the order of architects, Brussels



Léém Clay Plaster applied and finished purposely in a very rough way. Bar of Ancienne Belgique, Brussels

4.6.7 Surface treatments

Clay plaster systems are designed to remain without surface treatment. However, in demanding situations, it is possible to apply one, provided that it is not impermeable to water vapour.

Paints

Different type of paints can come on top of a clay plasters. Léém Clay Paint is exceptionally suitable (see section 4.8). In any case, the used paints must be permeable to water vapour. Typical examples are clay paints, lime whitewashes, silicate, casein and cellulose glue paints.

Fixatives

If extra strength is desired, fixatives can be used to prevent normal dusting of Léém Clay Plaster, or increase the surface strength (abrasion and impact) of Léém Clay Plaster, Finish and Paint. Cellulose- and casein-based fixatives are vapour open, are commonly used and available in the Léém product range.

Fixatives may be slightly visible, therefore a try-out on an invisible zone is recommended to foresee the visual impact.

Splashback resistant coat

If resistance against limited splashback water is required, waterglass-based (this is Sodium Silicate based) products as well as casein-based coatings can be applied locally and are available in the Léém product range. Waterglass coatings are not vapour open. Splashback resistant coats may be slightly visible, therefore a try-out on an invisible zone is recommended to foresee the visual impact.

Lime finishing coat

Fine lime mortar plaster 3-5 mm thick (e.g. Moroccan tadelakt, Japanese gloss plaster).

Tiling

Tiles on earth plaster are not recommended in areas subject to very high levels of humidity, such as shower areas. Tiles can be used as a protective coating on small surfaces (e.g. worktops), on masonry heaters and for decorative effects. Before gluing them to the Léém Clay Plaster, use the usual primer coat and subsequently the Léém Earth Adhesive Mortar.

[8]

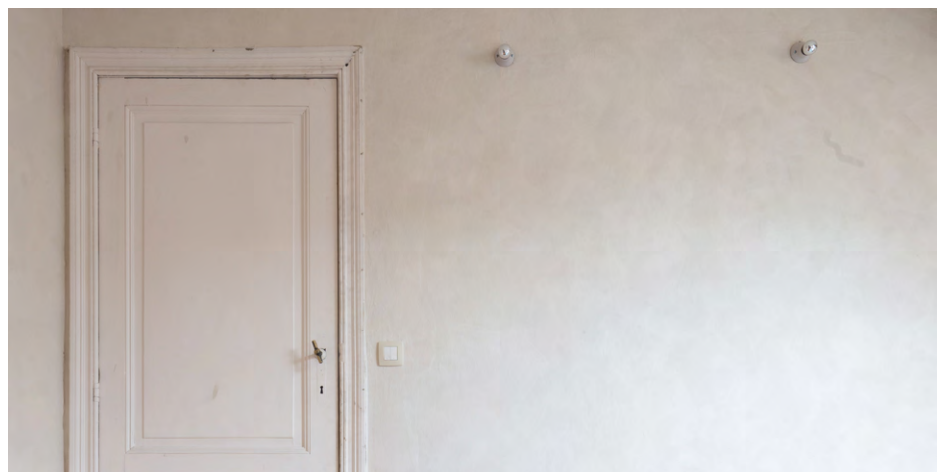

A Léém Clay Paint has been applied on top of clay plaster, gypsum fibre board and existing wall paint to homogenise the texture and colour of the space

4.7 Maintenance of Léém Clay Plaster & Finish

[5] Earth Building Practice: Planning - Design - Building.

Léém Clay Plasters can reach a considerable age. In Japan, where the use of lime was relatively uncommon, clay plasters have survived for centuries.

As with other internal room finishes, the expectation is that these will survive for decades without the need for appreciable maintenance. Exposed plaster surfaces have to be handled with care, avoiding damage to the surface where possible. When hanging pictures or other objects on the wall, holes should be carefully pre-drilled without using hammer action.

Due to the water-solubility of the Léém Clay Plasters & Finish and to a lesser extent Léém Clay Paint, repairs are generally simple to undertake. It is much easier to repair untreated surfaces than those that have been treated with a coating.

It is advisable to set aside sufficient material for later repairs, since the colour might slightly vary in future batches of Léém Clay Plaster. On smoothed surfaces only the damaged sections of the surface are smoothed over with a putty knife.

For rough surface finishes, the reworked sections of a wall are sponged down with wide sweeping movements after the application of a plaster or putty coat. The same technique can be used to refresh the colour of an entire surface, after gently pre-wetting the surface. When sponging, only a small amount of water is used and the sponge surface, as well as all other tools, must be kept very clean.

[5]



Reparation process of a scar in the Léém Plaster

4.8 Léém Clay Paint

Léém Clay Paint can optionally go on top of a clay plaster, or it can be applied on most substrates that have been mentioned for the Léém Clay Plasters in section 4.4.1. Typically, it is rather used as a time and material efficient finishing technique on surfaces that are already homogenized.

Substrate

To prepare the substrate, the steps described in section 4.4 can be followed. The substrate needs to be firm, rough, sufficiently absorbent and dry, and free of dust and contaminants. If a surface is not absorbent, it might be necessary to apply a primer.

Mixing

Léém Clay Paint is delivered as a fine dry mixture. We recommend to use batches of the same production dates to avoid possible colour differences. Similarly as for the Léém Clay Plaster & Finish, the dry mix should be mixed with water until you obtain a smooth, homogeneous paste that is pleasant to work with. Typically 40–60% of water should be added, depending on the substrate and application technique. Use a painter's mixer, a mixing attachment on a drill or a trowel by hand. For a more homogeneous, creamier coating mix with optimum performance, it is best to leave the mixture to settle for some minutes and mix again.

Application

Léém Clay Paint has a slightly textured appearance through the small grains in the mixture. It should be applied in one or two layers, when the underlying layer has properly dried out.

Typically, it is applied with a big brush, similarly as a lime wash. Use a crossing technique if you want to avoid a recurrent pattern.

Surface

Léém Clay Paint is not water resistant. Locally, for example close to a window opening, a fixative can be applied.

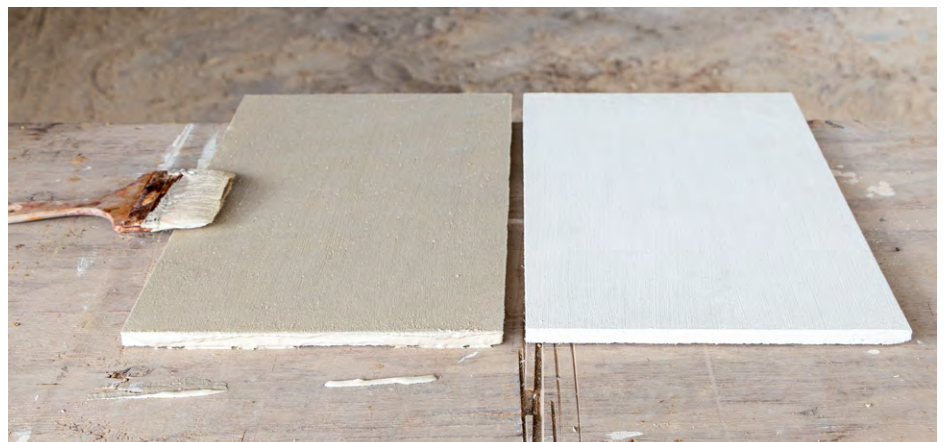

Léém Clay Paint will change colour when drying. Left is the freshly applied paint, right is the dry result.



Léém Clay Paint is delivered as a fine dry mixture of clay and local mineral materials



Application of the Léém Clay Paint with a wide brush



The Léém Clay Paint has been applied with rough brush strokes, these create a textured result

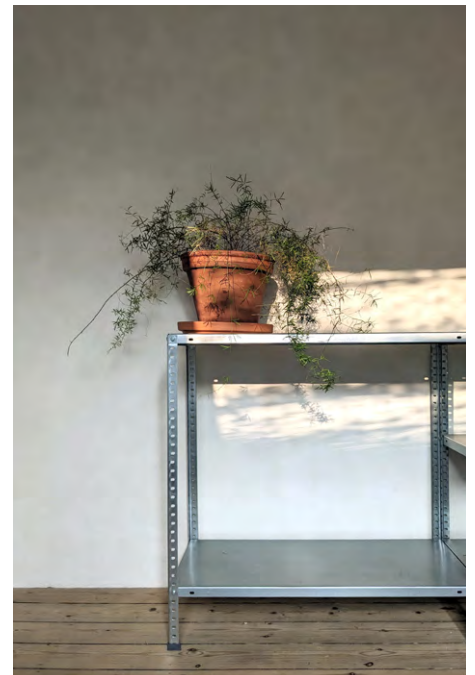

A Cream Léém Clay Paint applied to finish a room in a warm and soft tone

5.

Construction details



5.1 Léém Clay Plaster & Finish on masonry

[9] Sustainable Building with Earth.
[8] Cycle Terre. Guide de conception et de construction.

Substrate:

Léém Compressed Blocks, Léém Moulded Blocks, fired bricks, sand-lime blocks, concrete blocks and hemp-lime blocks are typically well-suited for receiving Léém Clay Plaster.

Substrate preparation:

As masonry has mostly flat, rough and absorbent substrates, it is usually sufficient to dust the surface and dampen it. However, if the surface is very smooth (for example clinker bricks), a slurry coat (gobetis) can be added to serve as a base for the Léém Clay Plaster.

Raking out the mortar joints to a depth of approx. 1 cm improves the mechanical adhesion of Léém Clay Plaster.

Light-clay blocks and hemp-lime blocks containing organic fibres are generally also good substrates. The rougher they are, the better the mechanical adhesion of the plaster. In some cases, they can be roughened in order to bring the fibre ends out of the substrate to improve adhesion. [9]

Plaster application:

For the base coat, Léém Clay Plaster is applied as explained in section 4.6, at a total thickness of 6 to 15 mm. In order to avoid ghost lines of the masonry joints, it is preferable to apply a second coat – a top coat. This 2 to 10 mm thick top layer can consist of Léém Clay Plaster or Léém Clay Finish. A coat can be added as soon as the previous one has dried completely (for drying times see section 4.6).

1: Masonry
2: Base coat (Léém Clay Plaster)
3: Top coat as finishing layer (Léém Clay Plaster or Léém Clay Finish)

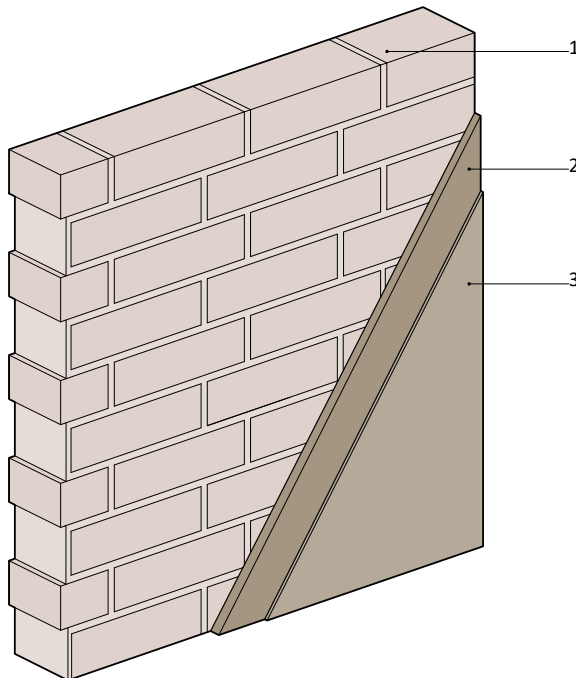

5.2 Léém Clay Plaster & Finish on concrete

[9] Sustainable Building with Earth.
[8] Cycle Terre. Guide de conception
et de construction.

Substrate:

Concrete is generally a difficult substrate for receiving Léém Clay Plaster since it is typically smooth and very little absorbent.

Substrate preparation:

The surface of concrete should be pretreated with a spray coat of cement slurry with coarse sand or fine gravel (2–4 mm) or with a Léém primer. The surface should first be removed from dust and checked for possible release agent residue which needs to be removed. [9]

Plaster application:

For the base coat, Léém Clay Plaster is applied as explained in section 4.6, at a total thickness of 6 to 15 mm. The 2 to 10 mm thick top layer can consist of Léém Clay Plaster or Léém Clay Finish. A coat can be added as soon as the previous one has dried completely (for drying times see section 4.6).

1: Concrete
2: Slurry coat
3: Base coat (Léém Clay Plaster)
4: Top coat as finishing layer (Léém Clay Plaster or Léém Clay Finish)

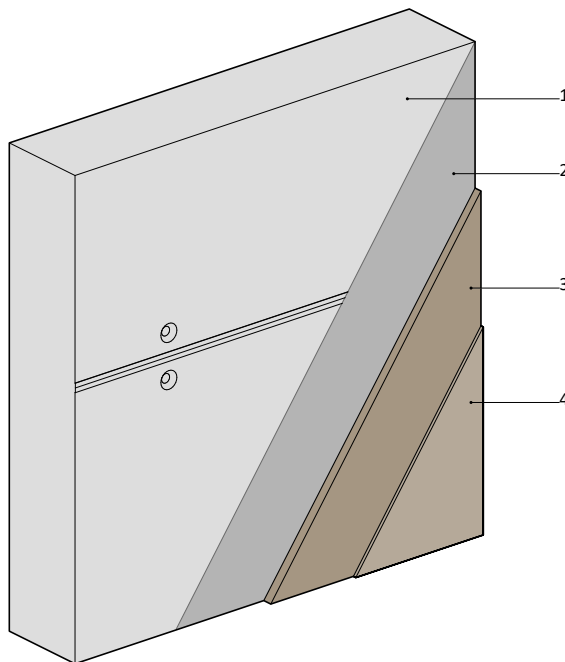

5.3 Léém Clay Plaster & Finish on stone wall

[9] Sustainable Building with Earth.
[8] Cycle Terre. Guide de conception
et de construction.

Substrate:

Rubble stone wall, old stone wall

Substrate preparation:

Stone walls can be more or less absorbent, uneven and rough, with potentially large joints. They always need to be dusted and humidified. If the surface is too smooth, it is recommended to apply a slurry coat. [9]

Plaster application:

Léém Clay Plaster is applied in two or three base coats (wait for complete drying between each layer), until the desired flatness is obtained, for a total thickness of 15 to 30 mm. If fibres are added, the applied base coat can be thicker (15 to 30mm per coat), which can help reducing the number of coats necessary. If wished, a top coat, consisting of Léém Clay Plaster or Léém Clay Finish, can be applied at a thickness of 2 to 10 mm. A coat can be added as soon as the previous one has dried completely (for drying times see section 4.6).

1: Natural stone
2,3,4: Base coat (Léém Clay Plaster)
5: Top coat as finishing (Léém Clay Plaster or
Léém Clay Finish)

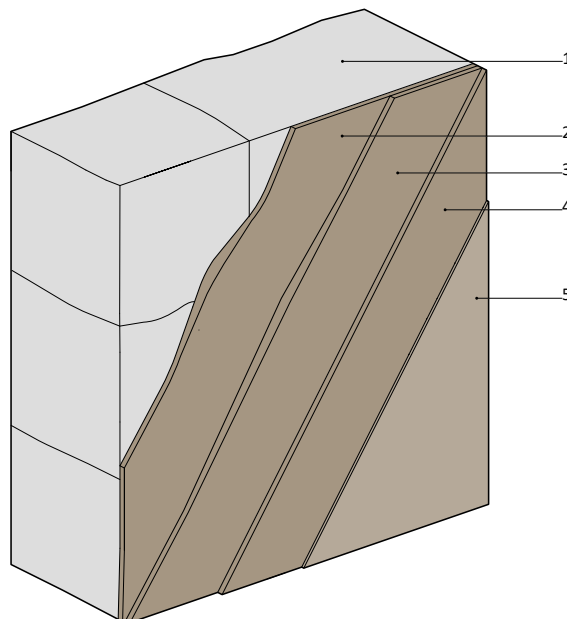

5.4 Léém Clay Plaster & Finish on earth wall

[9] Sustainable Building with Earth.
[8] Cycle Terre. Guide de conception
et de construction.

Substrate:

Rammed earth, cob, light earth
Typically well suited for receiving clay plaster.

Substrate preparation:

The flat, rough raw earth substrate should be dampened after making sure that it is dust-free (see section 4.4.2).

Before Léém Clay Plaster can be applied to newly constructed building elements made of rammed earth or light earth, the drying process and the accompanying shrinkage deformations or settling of the wall needs to be completed.

Due to the use of rammed earth for its aesthetic surface qualities, rammed earth structures have mostly been left unplastered in recent years.

Léém Clay Plaster adheres well to light-earth substrates due to the (fibre) aggregates contained in them, particularly after additional roughening of the surface. [9]

Plaster application:

For the base coat, the Léém Clay Plaster is applied as explained in section 4.6, at a total thickness of 6 to 15 mm. The 2 to 10 mm thick top coat can consist of Léém Clay Plaster or of Léém Clay Finish. A coat can be added as soon as the previous one has dried completely (for drying times see section 4.6).

1: Monolithic earth wall
2: Base coat (Léém Clay Plaster)
3: Top coat as finishing (Léém Clay Plaster or
Léém Clay Finish)

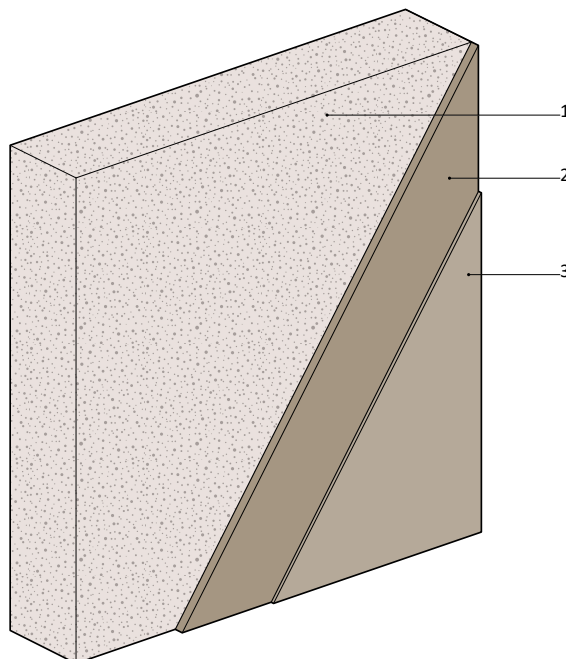

5.5 Léém Clay Plaster & Finish on drywall panels

[9] Sustainable Building with Earth.
[8] Cycle Terre. Guide de conception
et de construction.

Substrate:

Drywall panels can be used as a base for Léém Clay Plaster, but it is important to select a panel that is solid and can properly resist moisture. Therefore gypsum-fibre board is typically better suited than a common gypsum board.

Substrate preparation:

The substructure of the panels needs to be dense enough to carry the total weight of the panels and the plaster that will be applied. The panel joints need to be filled with compound, sanded according to the manufacturer's instructions and covered with reinforcement mesh. Applying Léém Flax Reinforcement Mesh across the entire surface is recommended.

The smooth, non-absorbent surface should not be dampened, but only dusted. A primer is applied to guarantee the adhesion of the plaster and to protect it from moisture penetration. The Léém Clay Plaster, Léém Clay Finish or Léém Clay Paint can be applied after the recommended drying time of the primer. [9]

Plaster application:

For the base coat, the Léém Clay Plaster is applied as explained in section 4.6, at a total thickness of 5 to 15 mm. The 2 to 10 mm thick top coat can consist of Léém Clay Plaster or of Léém Clay Finish. A layer can be added as soon as the previous one has dried completely (for drying times see section 4.6).

1: Metallic framework 2: Isolation
3: Drywall panels
4: Reinforcement fabric
5: Primer
6: Base coat (Léém Clay Plaster)
7: Top coat as finishing (Léém Clay Plaster or
Léém Clay Finish)
or 6 + 7: Léém Clay Paint

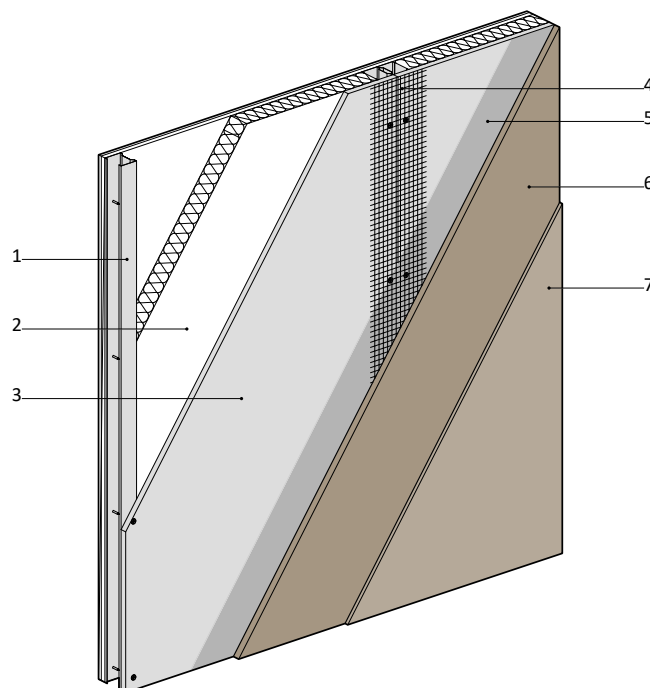

5.6 Léém Clay Plaster & Finish on earth panels

Substrate:

Earth panels are great substrates to apply Léém Clay Plaster on. They are vapour diffusion open, and the clay plaster will adhere well to it.

Substrate preparation:

The flat, rough surface should be dampened after making sure that it is dust-free. The panel joints should be covered with Léém Flax Reinforcement Mesh. The strips are placed flat over the joint and attached with the help of some Léém Clay Finish or Léém Adhesive Mortar.

Plaster application:

For the base coat, the Léém Clay Plaster is applied as explained in section 4.6, at a total thickness of 5 to 15 mm. An all-surface Léém Flax Reinforcement Mesh is pressed into the fresh plaster. The 2 to 10 mm thick top coat can consist of Léém Clay Plaster or of Léém Clay Finish. A layer can be added as soon as the previous one has dried completely (for drying times see section 4.6).

- 1: Wooden framework
- 2: Isolation
- 3: Earth panels
- 4: Base coat (Léém Clay Plaster)
- 5: Léém Flax Reinforcement Mesh
- 6: Top coat as finishing (Léém Clay Plaster or Léém Clay Finish)

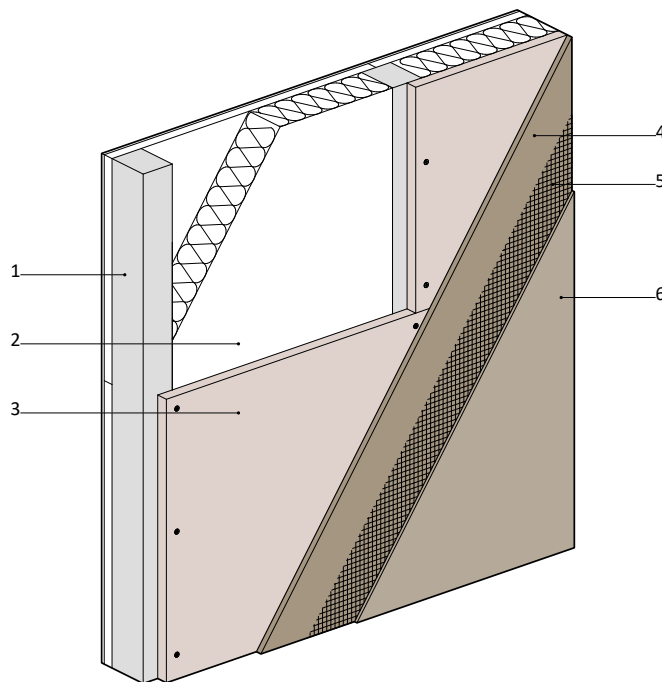

5.7 Léém Clay Plaster & Finish on wood-based panels

[9] Sustainable Building with Earth.
[8] Cycle Terre. Guide de conception
et de construction.

Substrate:

Wood-based panels (e.g. OSB, plywood, chipboard, etc.)
Cement- or lime-bonded woodwool panels

Substrate preparation:

Wood particle boards or oriented strand boards (OSB) are smooth and non absorbant surfaces. They are not intended for direct plaster application, a lath should be fixed to the panels to create a mechanical support for the Léém Clay Plaster.

On softwood fibre boards, a lath can also be used. Alternatively, the boards can get roughened so that the ends of the wood fibres stick out which creates better adhesion to the base coat. The substrate should not be pre-wetted.

Cement- or lime-bonded woodwool panels make good substrates. The panel joints should be reinforced with standard lath materials. Alternatively, Léém Flax Reinforcement Mesh can be embedded into the base coat across the entire surface. The substrate should not be pre-wetted. [9]

Plaster application:

The first layer of Léém Clay Plaster should cover the reed-mat completely. Once this layer has dried, a second layer of base plaster is applied at a thickness of 5 to 15 mm. An all-surface Léém Flax Reinforcement Mesh is pressed into the fresh plaster. Finally, a finishing layer, consisting of Léém Clay Plaster or Léém Clay Finish is applied.

- 1: Wooden framework
- 2: Isolation
- 3: Wood-based panels
- 4: Reed-matt
- 5: First base coat (Léém Clay Plaster)
- 6: Second base coat (Léém Clay Plaster)
- 7: Léém Flax Reinforcement Mesh in base coat
- 8: Top coat as finishing layer (Léém Clay Plaster or Léém Clay Finish)

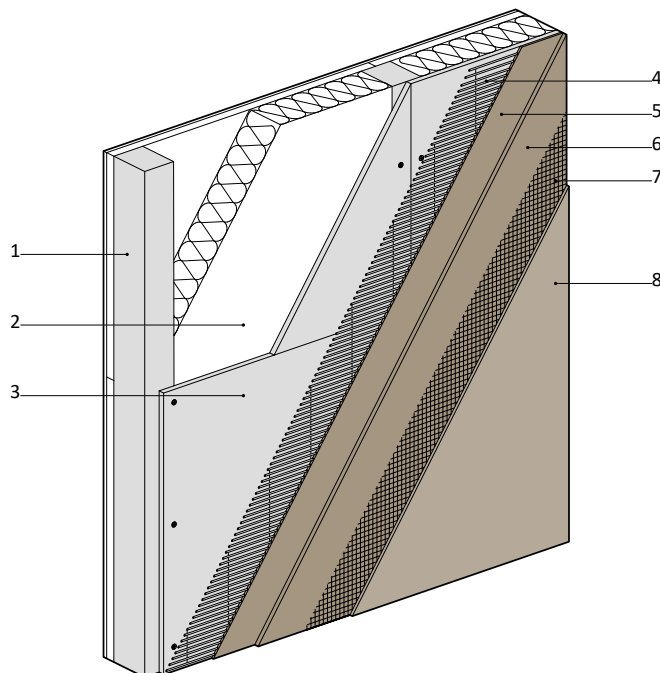

5.8 Léém Clay Plaster & Finish on straw bales

Substrate:
Straw bales

Substrate preparation :

Prepare the bales according to best practice by rectifying and surfacing the bales. After prewetting the surface, a slurry coat should be applied to serve as base for Léém Clay Plaster.

Plaster application:

Léém Clay Plaster is applied in two to three layers (wait for complete drying between each layer), at maximum thickness of 15mm, until the desired flatness is obtained. An all-surface Léém Flax Reinforcement Mesh is pressed into the fresh plaster. The 2 to 10 mm thick top coat can consist of Léém Clay Plaster or of Léém Clay Finish.

1: Straw bales
2,3,4: Base coat (Léém Clay Plaster)
5: Léém Flax Reinforcement Mesh
6: Top coat as finishing (Léém Clay Plaster or Léém Clay Finish)

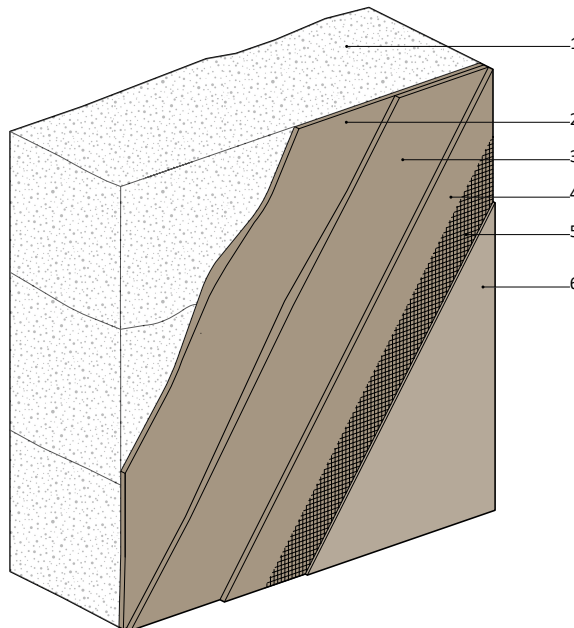

5.9 Léém Clay Plaster & Finish on wood frame structure

Substrate:

Timber frame, empty with (insulating) infill (light-earth, hemp-lime,...)

Substrate preparation:

To create a solid support for the plaster, a lath (see section 4.4.3) is fixed to the substrate. The Léém Clay Plaster will adhere to this lath, rather than to the wood structure or (insulating) infill.

In the case of a light earth infill, or other light insulation, the lath can be used as a formwork to install the infill.

Plaster application:

The first coat of Léém Clay Plaster should cover the reed-mat completely. Once this layer has dried, a second base coat is applied at a thickness of 6 to 15 mm. A Léém Flax Reinforcement Mesh is pressed into the fresh plaster. Finally, a finishing layer, consisting of Léém Clay Plaster or Léém Clay Finish is applied.

- 1: Wooden framework
- 2: Isolation
- 3: Reed-mat
- 4: First base coat (Léém Clay Plaster)
- 5: Second base coat (Léém Clay Plaster)
- 6: Léém Flax Reinforcement Mesh
- 7: Top coat as finishing (Léém Clay Plaster or Léém Clay Finish)

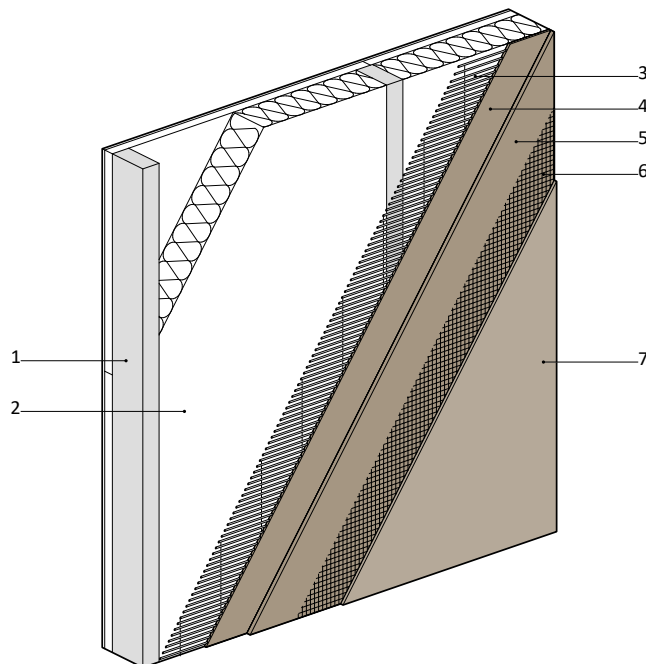

5.10 Léém Clay Plaster & Finish on a heated wall

Substrate:

Insulation (e.g. reed panels) to which heating pipes are fixed.

Substrate preparation:

The preparation steps depend on the nature of the substrate (see previous sections).

Plaster application:

The heating tubes are embedded in the first layer of Léém Clay Plaster, which is at least 10mm thick. Once this layer has dried, a second base coat of 6 to 15 mm thickness is added. A Léém Flax Reinforcement Mesh is pressed into the fresh plaster. The 2 to 10 mm thick top layer can consist of Léém Clay Plaster or of Léém Clay Finish.

- 1: Wooden framework
- 2: Isolation
- 3: Heating pipes
- 4: First base coat (Léém Clay Plaster)
- 5: Second base coat (Léém Clay Plaster)
- 6: Léém Flax Reinforcement Mesh
- 7: Top coat as finishing (Léém Clay Plaster or Léém Clay Finish)

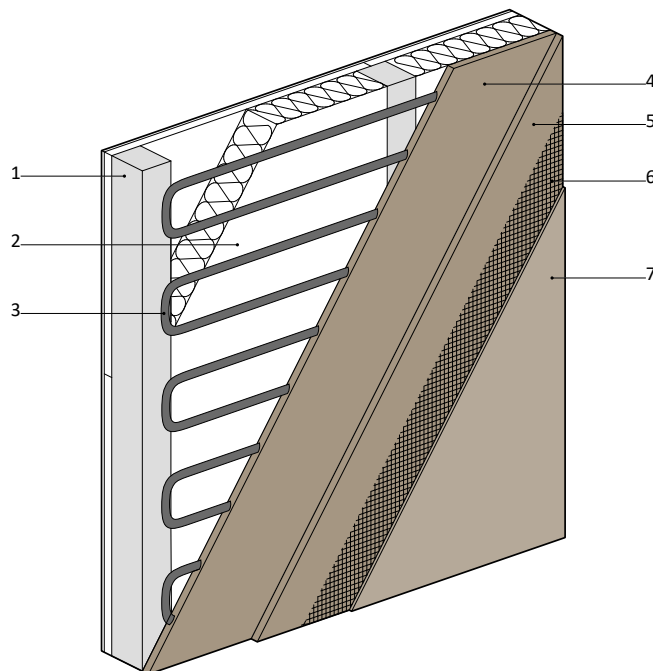



Earth panels are drywall panels that are screwed on a framework



OSB panels with reed lath stapled on it. The reed lath should be covered sufficiently (more than on this image) to create a homogenous base coat and avoid cracks



One base coat of Léem Clay Plaster Brown on top of hempcrete masonry. The ghost lines of the masonry joints shine through. To avoid this, at least two coats are needed.



Prototype of clay plaster on straw bales

6.

Bibliography

[1] Institut allemand de normalisation. DIN 18947: Mortier de terre pour enduit – Exigences, essai et étiquetage. 2018.

[2] Règles Professionels pour la mise en œuvre des enduits sur supports composés de terre crue

[3] e.V., Dachverband Lehm. Lehmbauregeln 2009. Wiesbaden : Vieweg + Teubner, 2009. DVL TM 06

[4] Buildwise (CSTC). NIT/TV 284: Les enduits intérieurs/Binnenbepfeisteringen. s.l. : CSTC, Novembre 2022.

[5] Ulrich Röhlen, Christof Ziegert. Earth Building Practice: Planning – Design – Building. s.l. : Beuth Verlag GmbH, 2011.

[6] American Clay: Technical information. American Clay. [Online] <https://www.americanclay.com/technical-information>. consulted in September 2023

[7] Urbane eco, sustainable building solutions [Online] <https://urbane-eco.co.uk/site/the-importance-of-breathability-in-building-fabric/> consulted in September 2023

[8] Cycle Terre. Guide de conception et de construction. Mai 2021.

[9] Schroeder, Horst. Sustainable Building with Earth. s.l. : Springer International Publishing, 2015.

7. Acknowledgements and credits

As mentioned in Section 1, this Léém Clay Plasters & Paint Guide is a compilation by BC materials of the most recent research publications, technical approvals and norms in Germany and France, updated with specific extra research and experience by BC materials and Buildwise related to a Benelux context. It would not have been possible without the specific input of following people. Thank you to

In Belgium, Lou Ricome, Lori Reding and Felipe Fernandez for the valuable work on the guide, Buildwise for the permission to reproduce schemes and tables from the NIT for clay plaster.

In France, Elodie Wallers, Teddy Dusausaye and Paul-Emmanuel Loiret of Cycle-Terre for their valuable exchanges and permission to use many schemes and details of CRAterre related to clay plaster and Sophie Bioul of Amaco for facilitation of the work on those schemes and details and sharing experiences of making the Cycle-Terre Guides.

In Germany, Dr.-Ing. Christoph Ziegert and Dr.-Ing. Horst Schröder for valuable input on DIN-norms and EPD-framework, and Ing. Stephan Jörchel of Dachverband Lehm bau for his facilitation.

This Guide has been funded by the EU – NextGeneration EU fund.



We have done our best to make clear all references of text and images in this guide. If no reference is found, BC materials can be considered to be the author. Please contact us on info@bcmaterials.org if you discover unreferenced or wrongly referenced text or images.

All images from bibliographic reference [8] have been kindly provided by Cycle-Terre and CRAterre and reworked by BC materials.

All content in this guide which has been created by BC materials is licensed under a Creative Commons Attribution-NonCommercial-ShareAlike 4.0 International License. Please contact us first if you would wish to use this content for commercial purposes.